

TOP

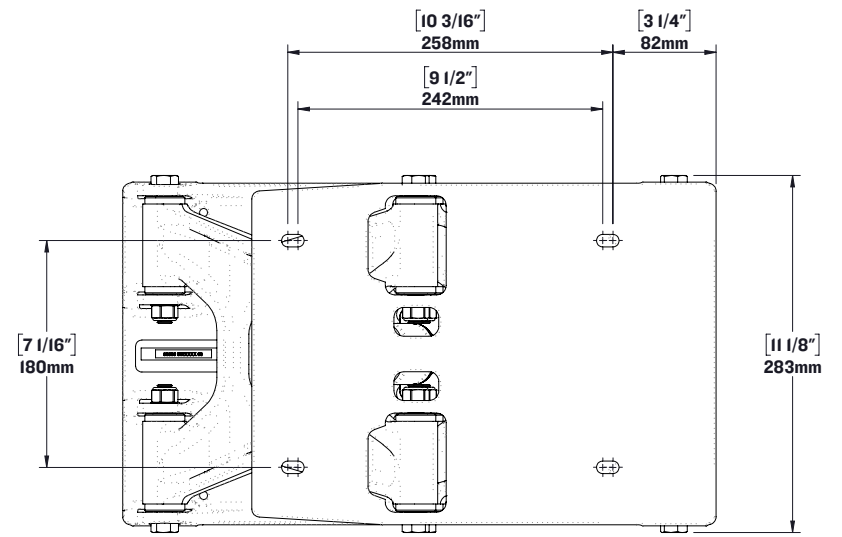

BOTTOM

NOTES:

1. ALL DIMENSIONED HOLES & SLOTS ARE 5/16"

SHOCKWAVE

FOR MORE INFORMATION
CALL US AT 1-778-426-8545
OR VISIT US ONLINE AT
WWW.SHOCKWAVESEATS.COM

PROPRIETARY AND CONFIDENTIAL

NOTICE: THIS DRAWING MAY REVEAL DESIGNS OR INFORMATION PROPRIETARY TO PROFESSIONAL COMPONENTS LTD. BY ACCEPTANCE OF REPRODUCTIONS, RECIPIENTS AGREE TO PROTECT PROFESSIONAL COMPONENTS LTD. RIGHTS AND ARE WARNED AGAINST USE OF THE DOCUMENT FOR ANY PURPOSE OTHER THAN THAT FOR WHICH IT WAS ISSUED.

SW-07823

S5 Sentinel Module

WEIGHT: [26.46 lbs] 12 kg

SCALE:1:6

SHEET 1 OF 1

REV: 00