

# ***SHOCKWAVE***

***MARINE SUSPENSION SEATING***

***S5*** | **S5-AL**  
**USER MANUAL**

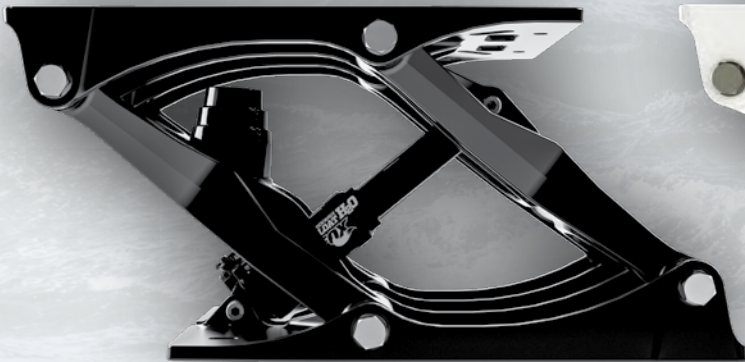

***FEEL BETTER. TRAVEL FARTHER.***

## Customer Service

At Shockwave, we've proven that innovation and attention to the highest safety standards can protect boaters from the shock of wave impact.

As avid boaters ourselves, we understand what our customers value most – and we create the best marine suspension seats in the world to provide a safer, more comfortable and exciting ride.

For customer inquiries and service support contact **+1.778.426.8544** or **support@shockwaveSeats.com**

Serial Number:

Address	<b>2074 Henry Ave. Sidney, BC Canada V8L 5Y1</b>
Website	<b>shockwaveSeats.com</b>
Sales	<b>+1.778.426.8545</b>
Reception	<b>+1.250.656.6165</b>
Hours	<b>8AM to 5PM PST</b>

## Included With Your S5-AL Purchase

- Shockwave S5-AL Marine Suspension Base
- Shockwave S5-AL User Manual
- Shockwave S5-AL Drill Template
- 2 Product Cards – Warning and Care Instructions
- 2 Decals – SHOCKWAVE (all purpose), SHOCKWAVE EQUIPPED (for your boat)

## Accessories Sold Separately

- Shockwave S5 S5-AL Shock Pump
- S5 Corbin Seat (High-Back & Mid-Back)
- S5 Corbin Seat with Heated Cushions
- SHOCKWAVE Swivel Slide, Swivel, and Slide
- Shock Extender Kit with Removal Tool
- Seat Adapter Kit

## Join the Shockwave Community

 [@SHOCKWAVESEATS](#)

 [@SHOCKWAVESEATS](#)

 [YOUTUBE.COM/SHOCKWAVESEATS](#)

# SHOCKWAVE

MARINE SUSPENSION SEATING

Important Instructions	4
Corrosion Prevention	6
Before You Start	7
Mounting Your Suspension Base	8
Setting Up the Suspension Base	9
Shock Compression Adjustment Settings	11
Rebound Adjustment	12
Service Tips	13
How to Clean Your Suspension Base	14
Drawings & Equipment List	14
Suspension Base Drawing (SW-07823)	15
Emergency Procedures/Troubleshooting	16
S5-AL Mounting Pattern	17
Caution & Warnings	18
Warranty & Warranty Policy	19
S5-AL Accessories & S5 Corbin Seats	20
General Boating Best Practices & Safety	22

## Important Instructions

### Footrest and Grab Handles

#### WARNING

All occupants are required to have footrests available, or feet placed on deck, at all times. The footrest surface should be 1" [25.4mm] - 6" [152.4mm] below the base of the S5-AL and 7" [177.8mm] - 16" [406.4mm] in front of S5-AL, and it should be a minimum of 16" [406.4mm] wide.

- (A) 1" [25.4mm] - 6" [152.4mm]  
(B) 7" [177.8mm] - 16" [406.4mm]



### Suspended Footrest

#### WARNING

Do not install any suspended footrest onto the S5-AL suspension base or seat mounted to the S5-AL. Footrests mounted to the base or seat will void the warranty.



### Fill Pump

#### WARNING

Do not leave pump attached when operating the seat, as it will damage the pump and fill valve.

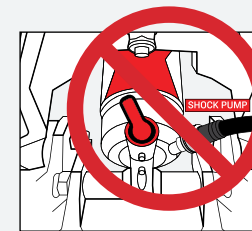

## Corrosion Prevention

Your Shockwave S5-AL leaves our factory with a coating of durable powder coat that should last for years. However, damage to this coating can allow corrosion to quickly take hold.

Here is a list of things you can do to prolong the life of your suspension base:

### Wash your S5-AL Suspension Base

Wash your suspension base with fresh water and apply Salt-Away as per instructions.

### Prevent Powder Coat Damage

- ✓ Use isolators which are provided when mounting your seat base to your boat, so that you do not scratch the coating.
- ✓ Prevent powder coat damage: Take care when inserting fasteners through slots to mount your seat. If your seat has studs protruding from the bottom of your seat, add a protective sleeve or tape the threads to prevent powder coat damage in the mounting slots.
- ✓ Do not allow metal washers to contact powder coat finish, as this will cut through the finish. If a metal washer is necessary, add a plastic washer in between.
- ✓ Apply TefGel: A liberal application of a corrosion inhibiting product like TefGel to the fastener threads can further reduce the chances of corrosion.

### Check for Stray Voltage

Stray voltage on the vessel can contribute to the speed of corrosion. Check to make sure your Zinc Anodes are not fully corroded. If they are, replace with new ones. If you are unsure of how to check the stray voltage on your boat use a multi-meter, or contact your local marina for assistance.

## Before You Start

The maximum occupant weight for the S5-AL suspension base is 250lbs [113kgs] on a vessel that sees maximum deck accelerations of 3g's. For calm waters and deck of accelerations less then 2g's, a 300lb [136kg] occupant is acceptable. When mounting a seat to the suspension base, always use the largest fasteners possible for the bolting configuration. The S5-AL bolt pattern can accommodate up to a 5/16" or M8 fastener.

Third party seats should be properly positioned on the suspension base with the center of mass being located across the main pivots shown by position (A).



**DANGER**

Any modifications done to the base that are not approved in writing by Shockwave, or installing a seat using incorrect bolting locations, can result in damage and injury and will void the manufacturer's warranty.





## Getting Started

Congratulations on your purchase of a Shockwave S5-AL marine suspension base. We hope you enjoy this new boating experience offering you access to new possibilities on the water.

### Mounting your Suspension Base

- There must be sufficient deck structure to support the weight of the seat and occupant within the vessels operational envelope.
- Thin or weak decks or mounting boxes should have large washers or reinforcement plates placed under the bolting surfaces to prevent fasteners from pulling through.
- Through-bolt the suspension base or bolt to stainless steel inserts bonded into the deck or equivalent structure, using the largest fasteners possible.
- There must be no flex in the seat mounting or deck plate when the seat is loaded.
- Do not attach any equipment to the suspension base.
- Do not mount the suspension base in the middle of an unsupported deck plate.
- Ensure that the movement of the suspension base does not interfere with the vessel structure or equipment.
- Properly torque the deck mount fasteners.
- Check the operation of the suspension base after installation to ensure it does not bind or stick.



#### **IMPORTANT**

Apply a quality marine grade sealant to all mating surfaces and hardware to prevent crevice corrosion.



#### **IMPORTANT**

The suspension base must not be modified.



Find 'how to' videos and other instructions on our website. Visit [www.shockwaveseats.com/howto](http://www.shockwaveseats.com/howto) for more information.

## Setting Up the Suspension Base

To achieve the best performance from the suspension base's shock absorber, the pressure should be adjusted to attain the proper sag setting. Sag is the amount the suspension compresses under the occupant's weight. Sag should be set at 20% of total shock travel. Proper sag level can be obtained by ensuring that the O-ring is at a distance of 0.5" from the shock cylinder body.



#### **IMPORTANT**

Warranty is void on suspension bases where incorrect installation causes damage to the base.



#### **DANGER**

Incorrectly installed suspension bases can cause serious injury or death and can cause damage to the vessel and the seat.



#### **IMPORTANT**

Strength of decks and deck mountings is the responsibility of the boat builder or installer of the seats. Shockwave assumes no liability for suspension bases that are incorrectly installed.



#### **DANGER**

Prior to use be sure to pressurize the shock absorber! Do not operate the seat without sufficient pressure in shock absorber or serious injury and damage to the suspension base will result.

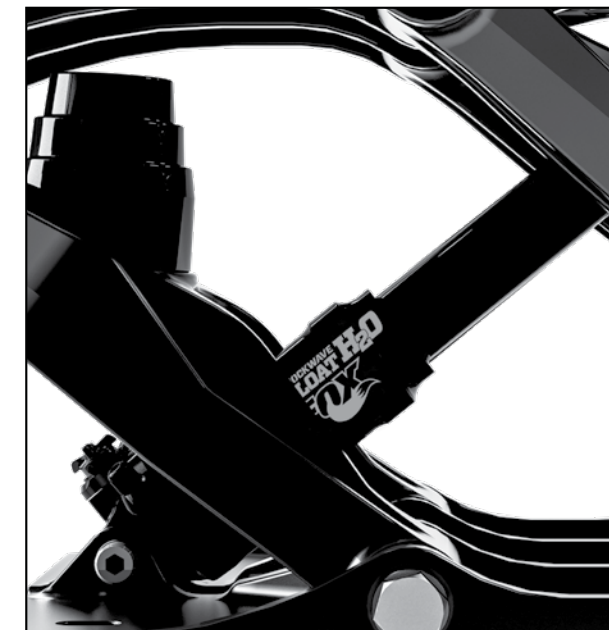

## Setting up the Suspension Base

- Turn the 3-position lever at the base of the shock absorber to the SOFT mode. See page 10.
- Install the pump and pressurize the shock absorber to 100 PSI. Then remove the pump.
- Cycle the shock absorber by bouncing on the seat 5 times. This will equalize the positive and negative air chambers.
- Use the pump to pressurize the shock absorber (in PSI) to match the weight in pounds (lbs) of the occupant. Remove the pump before step 5.
- Cycle the shock absorber by bouncing on the seat 5 times.
- Push the O-ring against the shock body.
- Gently sit on the seat.
- Gently get out of the seat.
- Check the sag percentage marking on the shock absorber shaft. Sag is correct if the O-ring sits at the 20% mark.
- If the sag value is not at the desired level, inflate or deflate the shock absorber in 10 PSI increments and repeat steps 5-8 until the desired sag level is achieved.

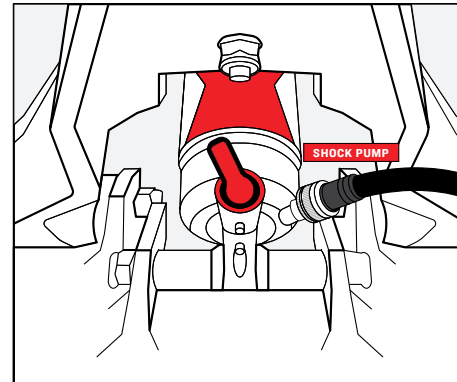

## Shock Compression Adjustment Settings

Setting the sag height is designed to be a starting point. To get the most out of the suspension base the shock absorber can be fine-tuned. This is done using a combination of compression and rebound tuning to optimize ride quality as well as for varying sea conditions.

The suspension base comes with a 2 or 3 position blue lever that is designed to make quick adjustments to optimize the performance of the shock absorber in varying sea conditions. You can select three settings:

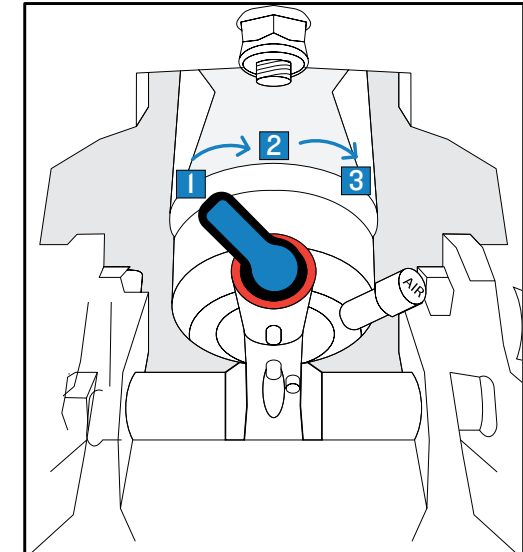

### 1 Soft mode

For operating in flat water and light chop where the likelihood of experiencing a slam is low. Mostly inshore use. Gives a soft ride.

### 2 Medium mode

For operating in moderate to rough conditions where some slamming could occur. Gives a medium ride.

### 3 Firm mode

For operating in big seas and at higher speeds where regular slamming will occur. Gives a firm ride.



**WARNING** Do not sit on the seat with the Shockwave S5-AL shock pump attached! Damage will occur to the shock and pump.

**WARNING** Do not exceed 325 PSI – the maximum shock absorber pressure.

**WARNING** Do not operate the S5-AL suspension base with shock pressure below 100 PSI.

## Rebound Adjustment

Rebound controls the rate of speed at which the shock returns to the sag position after compressing. The rebound adjustment is dependent on the air pressure setting. Higher pressure requires slower rebound settings. Use the procedure below to find the correct rebound setting.

### Faster Rebound

In high frequency and small wave activity, a faster rebound can improve your suspension performance.

Turning the red rebound adjuster counter-clockwise will make the seat rebound faster.

### Slower Rebound

In low frequency and large wave activity, a slower rebound can improve your suspension performance.

Turning the red rebound adjuster clockwise will make the seat rebound slower.

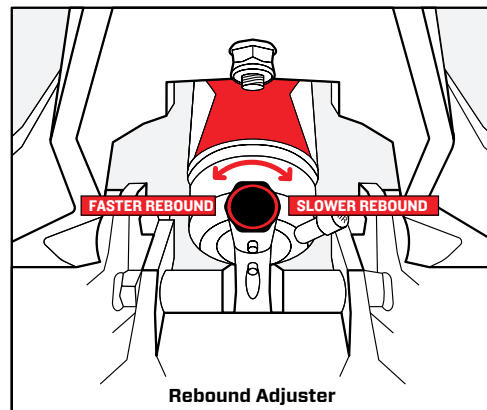

## Service Tips

**Cleaning:** Rinse your Shockwave S5-AL suspension base with fresh water after each use to prevent build up of salt and corrosion. Treat the suspension base with Salt-Away or similar protectant every month or as often as possible to prolong appearance and service life. To remove any dirt/salt build up on seat, use upholstery cleaner as required.

**Leaks:** The shock absorber should hold pressure and only need to be topped up occasionally. While it is recommended to regularly check sag and shock settings, the shock absorber does not require constant pressure adjustment.

**Shock Leaks:** Check the fill valve to see if debris is interfering with its operation or perform a simple soap solution test to identify the source of the problem. If a leak is found, replace the shock absorber or the fill valve core.

**Bolt Torque (Tightness):** All fasteners are prone to becoming loose from sustained high performance use. Shockwave recommends that all bolts should be visibly inspected for signs of being loose after every 125 hours of use. Always use a thread-locker on threads to prevent loosening of parts.



### WARNING

Do not sit on the seat with the Shockwave S5-AL Shock Pump attached! Damage will occur to the shock and pump. Note, Shockwave Pump sold separately.



### IMPORTANT

Be sure to wash your suspension base properly. Thoroughly wash base with fresh water and boat or car wash detergent, removing all contaminants and surface corrosion.



### IMPORTANT

Following CLEANING instructions is the most important way to maximize seat life.

## How to Clean Your Suspension Base

- Using a soft cloth, wipe all surfaces of the S5-AL suspension base with fresh water. Open deck boats can hose off suspension bases if needed.
- Allow to dry.
- Spray LPSI, Salt-Away (or equivalent) corrosion inhibitor on terry or microfiber cloth and wipe all metallic and painted surfaces and hardware.
- Ensure all areas surrounding bolt heads and nuts are thoroughly cleaned and lubricated to decrease chance of corrosion.
- Gently wipe shock shaft with a thin layer of LPSI, Salt-Away (or equivalent) corrosion inhibitor. Clean off excess to avoid particulate from sticking to the shock shaft during operations.
- All accessories (slide, swivel slide) can have LPSI, Salt-Away or equivalent applied.
- Application of LPSI or Salt-Away should occur after every trip or once every 30 days.
- Wipe S5 Corbin seats with marine grade upholstery cleaner.
- \*Optional: All bolt heads and nuts can be coated with LPS3 if desired for added corrosion resistance.

## Drawings & Equipment List

The illustrated parts breakdown is designed to provide a functional overview of the Shockwave S5-AL marine suspension base and provide a reference to points covered in the user manual. These drawings show:

- The name and location of major components
- A breakdown of the major components in your suspension base order

These drawings can be used to order spare parts and replacements.

## Suspension Base Drawing (SW-07823)

QTY	PART NO.	DESCRIPTION	
1	16	SW-04747	S5 pivot bushing
2	8	SW-04748	S5 bushing spacer
3	1	SW-04754	S5 bump stop
4	1	SW-04893	S5 product card assembly
5	1	SW-07825	S5-AL cast H-Arm AFT
6	1	SW-07826	S5-AL cast H-Arm forward
7	1	SW-07828	S5-AL cast plate base
8	1	SW-7829	S5-AL cast plate top
9	1	SW-7830	S5-AL shock absorber
10	1	FA-M8X60-AS-CS-SS	Screw, socket head cap
11	1	FA-M8X110-AS-CS-SS	Screw, socket head cap
12	1	FA-M10X30-AS-CS-SS	Screw, socket head cap
13	8	FA-MI2X110-HH-CS-SS	Bolt, hex head
14	2	FA-3/8-FW-AN960C6I6	Washer, flat
15	16	FA-1/2-FW-AN960C8I6L	Washer, flat
16	4	FA-5/16-FW-AN960C5I6	Washer, flat
17	2	FA-M8-LN-SS	Nut, nylock
18	1	FA-M10-LN-SS	Nut, nylock
19	8	FA-MI2-LN-SS	Nut, nylock

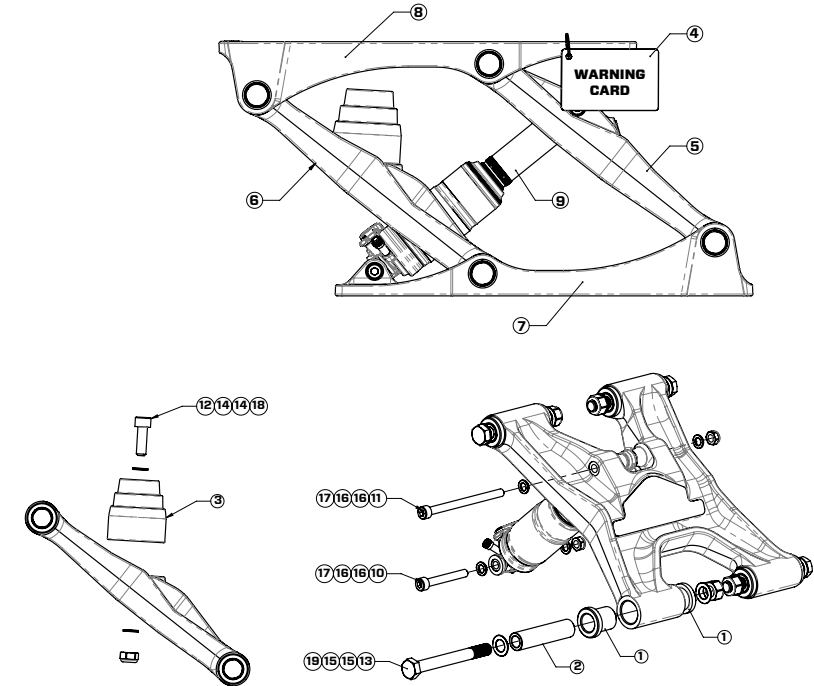

PROPRIETARY AND CONFIDENTIAL

NOTICE: THIS DRAWING MAY REVEAL DESIGNS OR INFORMATION PROPRIETARY TO PROFESSIONAL COMPONENTS LTD. BY ACCEPTANCE OF REPRODUCTIONS, RECIPIENTS AGREE TO PROTECT PROFESSIONAL COMPONENTS LTD. RIGHTS AND ARE WARNED AGAINST USE OF THE DOCUMENT FOR ANY PURPOSE OTHER THAN THAT FOR WHICH IT WAS ISSUED.



## Emergency Procedures/Troubleshooting

Condition	Cause	Solution(s)
Suspension base is lower than normal or shock absorber will not pressurize	Leak in system Worn or corroded fill valve Defective shock absorber Faulty pump	Check system for leaks by applying soapy water to system connections and look for bubbles. If a leak is found, replace the shock absorber  Remove the fill valve core and replace with a new one from an auto supply store  Replace the shock absorber – this is required only on extremely rare occasions
Suspension base is bottoming out	Shock pressure is too low	Attach pump and add air as per instructions on page 7 of this manual
Suspension base is topping. Ride is rough and erratic. Noise heard or shock felt when seat comes to top of travel	Shock pressure is too high	Reduce shock air pressure
Seat is “bucking off” or bouncing occupant	Rebound speed is too fast	Adjust red rebound adjuster as per instructions on page 12 of this manual
Squeaking noise when underway	Loose components Shock absorber mounting bolts are dry	Tighten loose components Apply marine grade grease to shock mounting bolts
Moving components or accessories will not move	Bearing or sliding mechanism is corroded, dry or binding	Disassemble if necessary and lubricate with marine grade grease

## S5-AL Mounting Pattern

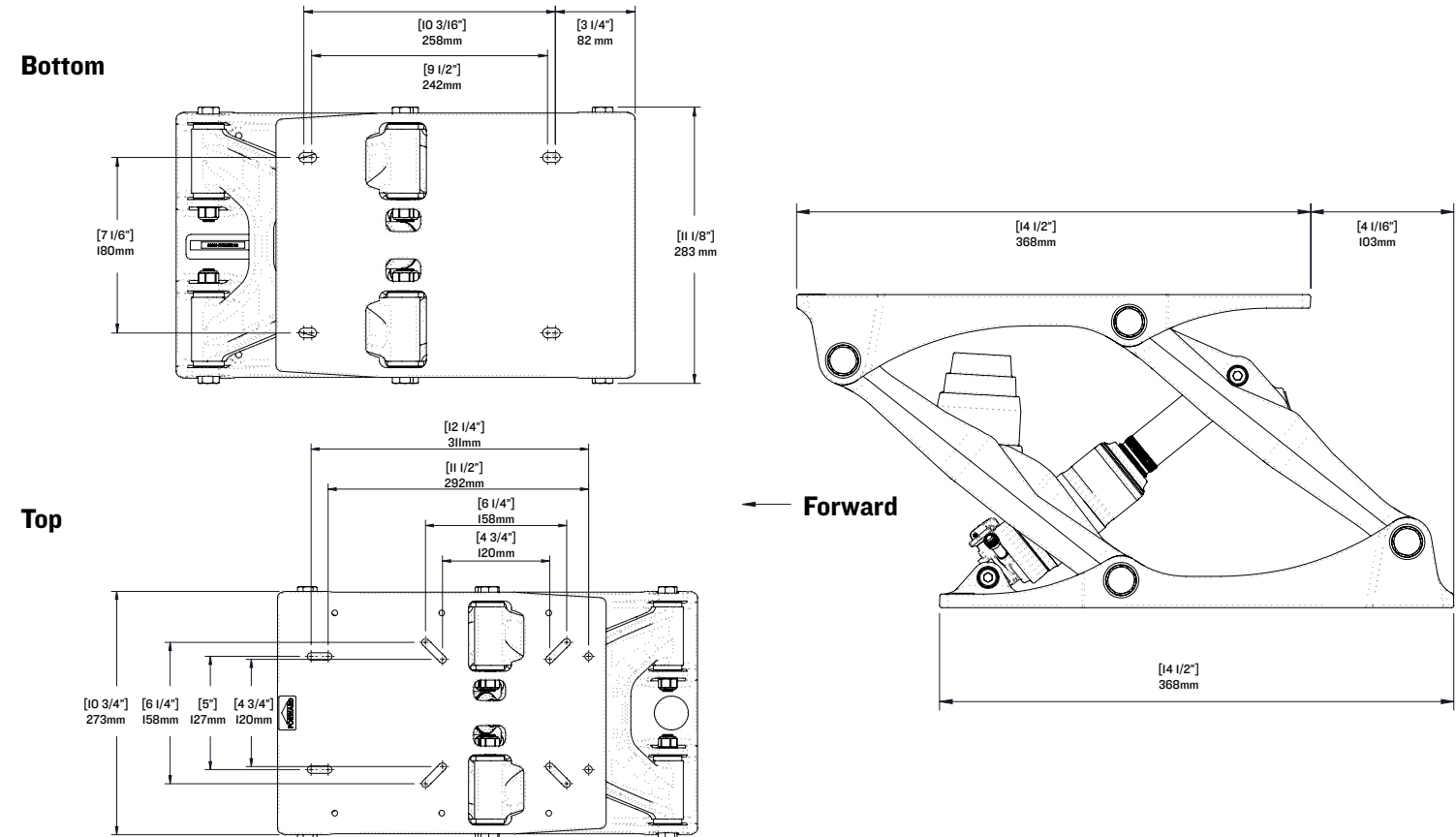

## Cautions & Warnings

Your Shockwave S5-AL marine suspension base will mitigate the effects of shock and vibration, reducing the potential of injury, but it will NOT prevent the possibility of injury. The increased level of comfort and control provided by Shockwave S5-AL marine suspension seating will allow the craft to operate at higher speeds in sea states which create high shock loads on the craft and potentially the occupants. **High shock loads could potentially exceed the seat's capability to mitigate.**

Operating marine craft in a high shock load environment is inherently hazardous. Tolerance to the effects of shock and vibration vary from person to person and it is the responsibility of the craft operator to ensure the safety of each person on board. Pain and/or discomfort are indicators of a potential injury. Constantly monitor the physical state of the craft and the personnel on board. Hazardous operation of the craft may result in serious injury, death or damage to the craft.

### DO NOT

- Operate seat without sufficient pressure in shock absorber or serious injury and damage to suspension base will result.
- Place hands near base when in use. Serious injury can result.
- Modify the equipment by drilling any holes, removing material, or adding extra equipment. Serious injury can result.
- Use the suspension base if it is or appears to be damaged. Serious injury can result.
- Use the suspension base if the base to deck attachments are loose. Serious injury can result.
- Use the suspension base if base resting height is lower than normal. This may be an indication of a damaged shock and serious injury can result.
- Operate the suspension base with insufficient air pressure in the shock to prevent bottoming. Serious injury and damage to the seat can result.
- Use the suspension base for uses other than its intended purpose. Use of the seating for other than its intended purpose may result in damage to the equipment or bodily harm.
- Use the suspension base if fasteners are loose. Damage to the equipment or bodily harm may result.

- Attempt to open, perform maintenance or repair the suspension base while craft is underway. Damage to the equipment or bodily harm may result.
- Place items under or around the suspension base that may interfere with the suspension base's range of motion. Damage to the equipment or bodily harm may result.
- Operate the seat if the occupant's weight exceeds 250lbs [113kgs] for 3g deck accelerations or 300lbs for 2g accelerations.
- Mount footrests directly to seats.

 **IMPORTANT** Follow IMPORTANT instructions located throughout this User Manual to prolong the appearance and service life of your Shockwave S5-AL marine suspension base.

## Warranty & Warranty Policy

Shockwave Seats expressly warrants that all mechanical seat components in its Marine Suspension Seats shall be free from defects in material and workmanship for one year from the date-of-sale, provided such seats are subject to normal use and receive proper maintenance.

Shockwave Seats expressly warrants that the cushions and seat covers shall be free from defectively sewn seams for a period of 90 days or 750 hours of use, whichever comes first, excluding normal wear and tear. Rips, tears, abrasions and installation damages are not covered by this warranty.

The Suspension Base **powder coat finish** is not covered by warranty if corrosion is a result of abuse or lack of maintenance. Suspension Bases must be cleaned with fresh water after every use.

Your sole and exclusive remedy against Shockwave Seats arising from the purchase or use of Marine Suspension Seats is limited to repair or replacement of defective materials or defective workmanship, after verification by Shockwave Seats. Defective product or materials may be requested for return by Shockwave Seats for inspection prior to issuing any replacements. Freight charges for returns are to be covered by the user.

All warranty claims shall have prior approval from Shockwave Seats warranty department and must be accompanied by the information requested on the following Claim Form. Products will be repaired or replaced at the sole discretion of Shockwave Seats.

These warranties will become null and void if:

- The seat is abused or altered
- The seat is involved in an accident
- The seat is improperly installed
- The seat is used for other than its intended use, contrary to any of the instructions in the manual provided
- There is damage to the cushions and covers caused by cuts, burns, or abuse
- There is damage to the seat caused during installation or unpacking
- There is damage to the structural integrity as a result of the user installing unapproved accessories
- Footrests are mounted directly to seat

- Occupant weight exceed 250lbs [113kgs] for 3g deck accelerations. For calm waters and deck of accelerations less than 2g, a 300lb [136kg] occupant is acceptable
- Damage results from incorrect installation of Shockwave accessories

### Warranty Disclaimers and Limitations of Liability

The above expressed warranties shall be the exclusive warranties, and Shockwave Seats makes no other warranties, expressed or implied. Shockwave Seats expressly disclaims and implied warranties of merchantability and implied warranties of fitness for a particular purpose.

It is agreed that Shockwave Seats shall not be liable for incidental or consequential damages, including, but not limited to, loss of income, loss of use, lost profits, damage to other property, the cost of removing and reinstalling Marine Suspension Seats, attorney's fees, and any liability you may have with respect to any other person.

### Time Limit on Commencing Legal Action

It is agreed that you have one year from the accrual of a claim to commence any legal action arising from the purchase or use of the Marine Suspension Seats. Failure to give prompt written notice within ten (10) days of the discovery of any defect in material or workmanship that occurs within the warranty period will void the warranty. Send notification to:

### Shockwave Seats Warranty Department

2074 Henry Avenue West, Sidney, BC, V8L 1T2, Canada  
✉ support@shockwaveseats.com ☎ +1.778.426.8544

### Warranty Claim Form Must Be Submitted

Download your Warranty Claim Form at [shockwaveseats.com/warranty](http://shockwaveseats.com/warranty)

## S5-AL Accessories



### Shock Pump | SW-01983

The high-pressure shock pump features an integrated pressure gauge and bleed valve for simple adjustment with a maximum inflation pressure of 350 psi. A Shockwave shock pump is required to operate the S5-AL.



### Shock Extender Kit With Removal Tool | SW-08397-PKG

The Shockwave S5 Shock Extender Kit will allow you to raise your suspension base 1.5", which means that you can lift the height of the base from 8.5" to 10".



### Seat Adapter Kit | SW-08290

The Adapter Kit allows users with non-Shockwave brand seats that have a 5x12" bolt pattern to fit to Shockwave Swivels and Slides. The Adapter Kit accommodates both upward and downward bolt patterns.



### Swivel Slide | SW-05488

This Swivel Slide system has 5-inches of fore-aft travel and features premium track and cars for smooth operation. The 360-degree swivel has a positive lock that engages every 22.5° (16 positions).



### Slide | SW-05489

Our purpose-built Slide offers a full 5-inches of fore-aft travel, allowing for comfortable seating options for a wide variety of occupants and users. Our Slide pairs perfectly with the S5-AL and the S5 Corbin Seat.



### Swivel | SW-05592

This robust 360-degree Swivel is designed to pair with the S5-AL and the S5 Corbin Seat. A positive lock engages every 22.5° (16 positions).

## S5-AL Accessories & S5 Corbin Seats



### Footrest | SW-07507

Our height adjustable folding footrest has 6" of travel and is foot operated for ease of use. It offers a stable platform 17" wide and is designed to be bulkhead mounted on a console.

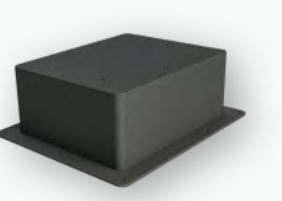

### Riser Boxes

6" SW-07251 | 9" SW-07920

Shockwave offers 6" and 9" riser boxes for customers needing additional height below their seat.



### Cup holder with Aluminum Bracket | SW-01688

Shockwave offers an optional Cup Holder that can be attached to either side of the armrest of the S5 Corbin Seat.



### S5 Corbin Seat – Mid-back

Black SW-04920-B | White SW-04920-W  
Heavy Duty SW-04920-HD

Designed to pair perfectly with the S5-AL suspension base, the S5 Corbin Seat is a lightweight, robust boat seat that comes equipped with folding armrests, a storage pocket, machined aluminum seat frames, fiberglass seat backs, and Corbin cushions.



### S5 Corbin Seat – High-back

SW-06328-B

This seat is perfect for long days on the water when neck and head support is preferred.



### Seatbelt | SW-00774

For those who need an extra level of safety and security, seatbelts are available for all Shockwave Seats. Constructed with 100% non-ferrous material.



## General Boating Best Practices & Safety

Shockwave marine suspension bases are designed to mitigate shock and vibration encountered in high-speed vessel operation in rough seas. Following the suggestions in this section will ensure that you are getting the most out of the product.

### **Operate in the vessel's operational envelope.**

Driving a boat beyond its limitations can have damaging effects on the hull, engines and equipment. Shockwave Seats are designed to provide shock mitigation to the occupant. They will not protect the occupants from injury caused from operating the vessel outside of its operational envelope.

**Operate the vessel in your crew's physical conditioning envelope.** Personal fitness is a limiting factor to the amount of sustained G loads a person can endure without injury. If you have inexperienced, relatively unfit or overweight persons aboard, extra caution must be exercised to prevent injury. The helmsman must be keenly aware of the shock loads being transmitted to others not in a suspension seat or standing as serious injury can occur. Installation of Shockwave Seats provides an extra level of protection but they will not protect a person from ALL shock loads.

### **Operate in your own ability envelope.**

Shockwave Seating will increase the confidence of the helmsman. Sometimes over confidence can lead to loss of control. Generally, the seats will permit greater control of the vessel and the helmsman should focus on using the control

advantages of shock mitigated seating to better look after the vessel and crew.

**Do not sit in seats with hard or sharp objects. Do not walk on seats.** Ensure that sharp objects and heavy gear are worn so that they will not tear upholstery.

**Do not tie the boat up with the suspension base.** As tempting as it may be Shockwave Seats are not designed to tie up the boat. A sudden surge or wave will likely bend the seats or attachment brackets and compromise performance.

**Tie everything down.** Pay attention to how you have stowed your gear. Elastic shock cords and ratchet tie-downs should be used to secure all gear. Plastic containers of oil and other fluids must be protected from chafing and puncture. Electronic equipment must be secured to prevent damage from shock loads.

**Check all equipment.** Conventional mounting brackets for heavy items such as fire extinguishers are subject to much more loading than without shock mitigation. Make sure all of your equipment brackets are tight. Recheck major equipment bolts regularly. Wiring, cables and fluid hoses should be bundled tightly and not allowed to flail. Do not allow any objects

under the seats or footrests as they will limit the stroke of the seat and damage the objects or the seat.

**Ensure that the suspension base is functioning properly.** Refer to the Caution Notes in the next section. The following is provided as a general checklist. Providing you have done everything correctly in the Caution Notes – do not operate the seat if:

- The shock absorber setting or sag is incorrect
- Components are loose, broken or missing
- The suspension base makes a strange noise

**Use seatbelts.** If supplied - seat belts prevent occupants from being ejected from the vessel and the seat. When not in use, the seat belt buckle ends should be fastened to prevent damage to the suspension base.

**Adjust height and fore and aft correctly.** If supplied - correct ergonomics and posture enhances the ability to operate the vessel safely and reduces the risk of shock and vibration related injury. Take the time to adjust the seat on the suspension base so that it's comfortable.

**Rinse the suspension base with fresh water after each use.** Rinse the suspension base with fresh water after each use or every week if being stored outside to prevent a buildup of salt and debris.

# JOIN THE SHOCKWAVE COMMUNITY

 [@SHOCKWAVESEATS](#)

 [@SHOCKWAVESEATS](#)

 [youtube.com/shockwavesSeats](https://youtube.com/shockwavesSeats)



# ***SHOCKWAVE***

*MARINE SUSPENSION SEATING*